

**A book
isn't a book
isn't a book**

Manuel Schmalstieg

Greyscale Press

**HEAD — haute école
d'art et de design**

#ebook

#print-on-demand

#print-on-demand

**MY LIFE
IN TWEETS**
JAMES BRIDLE

VOLUME I
FEBRUARY 2007 - 2009



James Bridle, 2009

```
<?php
```

```
/* -----
```

```
JAMES' SCRIPT FOR GETTING TWEETS
```

```
Change the .txt suffix to .php, obviously.
```

```
To use this script, you need API access to Twitter (http://apiwiki.twitter.com/)
```

```
Replace YOUR_TWITTER_USERNAME and YOUR_TWITTER_PASSWORD with, you know, your Twitter username and pas
```

```
Each "page" is 20 tweets, exactly as seen on http://twitter.com/home, http://twitter.com/home?page=2,
```

```
You can only make 100 API calls an hour, so you can only get 100 pages an hour, so change PAGE_TO_STA  
and run the script, copying and pasting the output somewhere else. Then wait an hour, change to 100  
you've got all your tweets (when blank pages start appearing).
```

```
Made by James from http://booktwo.org, as used on http://booktwo.org/notebook/vanity-press-plus-the-t
```

```
----- */
```

```
$login = "YOUR_TWITTER_USERNAME:YOUR_TWITTER_PASSWORD";
```

```
$page = PAGE_TO_START_AT;
```

```
$endpage = PAGE_TO_STOP_AT;
```

```
while ($page < $endpage) {
```

```
$target = "http://twitter.com/statuses/user_timeline.xml?page=" . $page;
```

```
echo '<p>' . $page . ': ' . $target . '</p>';
```

```
$ch = curl_init();
```

```
curl_setopt($ch, CURLOPT_URL, $target);
```

```
curl_setopt($ch, CURLOPT_USERPWD, $login);
```

```
curl_setopt($ch, CURLOPT_RETURNTRANSFER, TRUE);
```

```
$gettwit = curl_exec($ch);
```

FIFTEEN
MINUTES
COULD
SAVE YOU
HALF AN
HOUR OR
MORE

JANUARY 16, 2010
—MAY 23, 2011

Ether Press, 2011

INDEX

Right, 25
 r, 2, 3
 rain, 14
 ready, 6, 11
 reality, 20
 really, 3, 4, 13, 14, 19
 reckless, 3
 red, 5
 released, 25
 releaseing, 12
 relocated, 25
 remember, 2
 retarded, 25
 rev, 3
 reversing, 7
 rice, 12
 right, 5, 26
 rock, 13
 routine, 19

 S, 7, 13, 25
 SELL, 25
 SOUP, 1
 SPONGEBOB, 6
 SQUARE, 6

 SUPER, 13, 26
 Seeing, 14
 Shopping, 11
 Sincerely, 5
 So, 1, 5, 7, 13, 25
 Someone, 5
 Sooo, 4
 Sooooooooooooo, 25
 Soundcheck, 6
 Speak, 1
 Speech, 25
 Still, 4, 5
 Sunday, 19
 Supernatural, 14
 Sydney, 5, 6, 12
 sad, 6
 said, 6, 12
 sale, 13
 salt, 14
 same, 12
 sand, 7
 savinggg, 19
 saw, 2, 4
 say, 4, 11
 scary, 26

INDEX

there, 2, 4, 5, 11
 there's, 6, 11
 they, 3, 20
 thing, 5
 think, 2, 7, 12, 25
 this, 1, 2, 3, 12, 14
 tho, 4, 6
 though, 13
 through, 1
 ticket, 25
 till, 1, 19
 time, 1, 2, 12, 26
 times, 5
 tix, 1
 today, 2, 3, 4, 13, 14, 20, 25, 26
 tomorrow, 3, 14, 20, 25
 tonight, 6, 11, 13, 14
 too, 5
 took, 13
 top, 25
 totally, 2, 13

 touch, 13
 tour, 4
 touring, 3
 train, 13, 20
 transformers, 19
 travel, 19
 tried, 13
 trip, 26
 trips, 20
 true, 1
 trying, 2
 turn, 5, 13
 turned, 3, 25
 turning, 3, 4
 turns, 7
 tut, 3
 tuts, 25
 twitpic, 3
 twitter, 1, 5
 tzatziki, 13

 U, 3
 UCMF, 2
 UNkeen, 25
 USA, 3
 Ur, 4

Enter your email address

Enter your Twitter screenname (only public streams, for now)

Title your book





by @PeterTurner

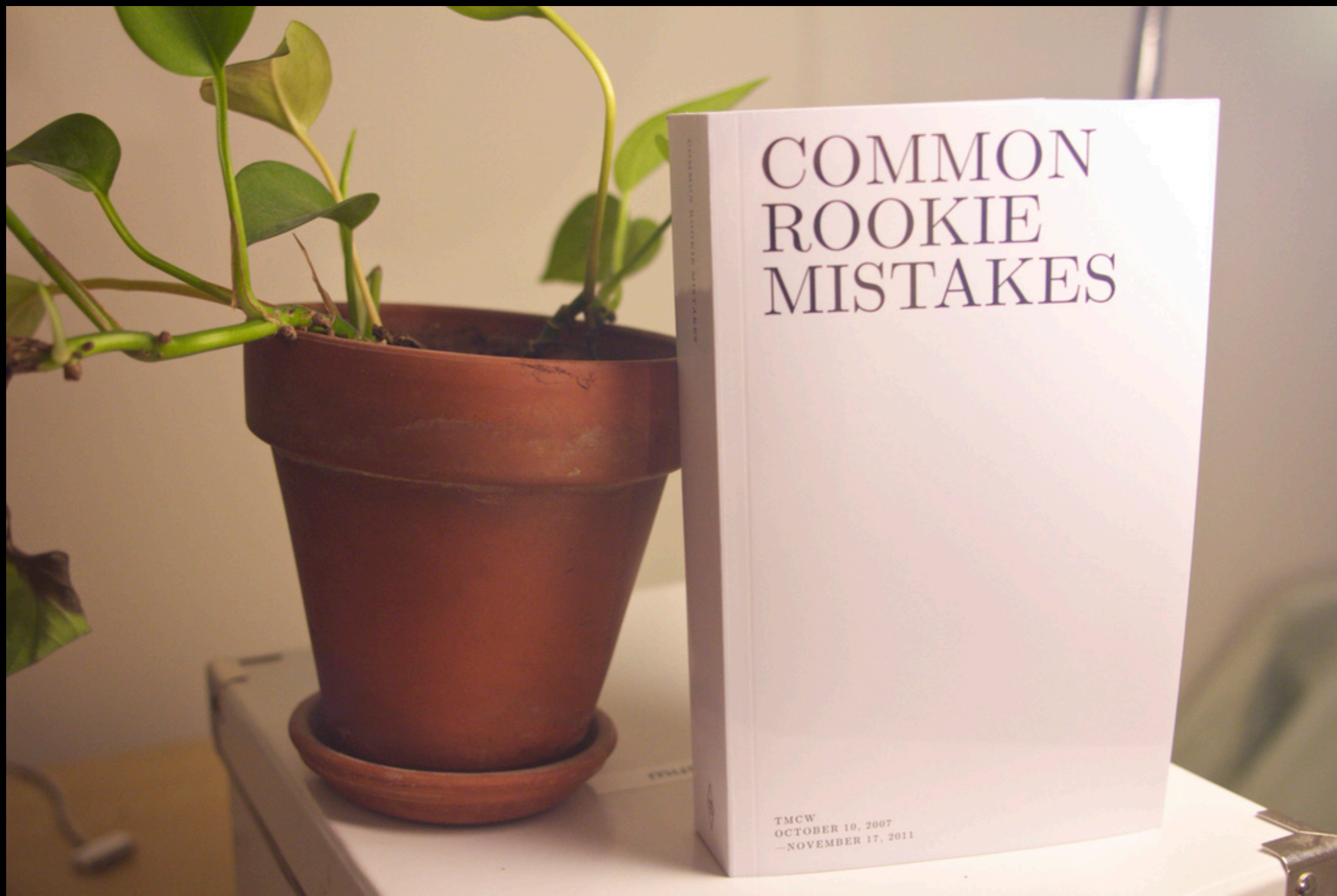

by @tmcw

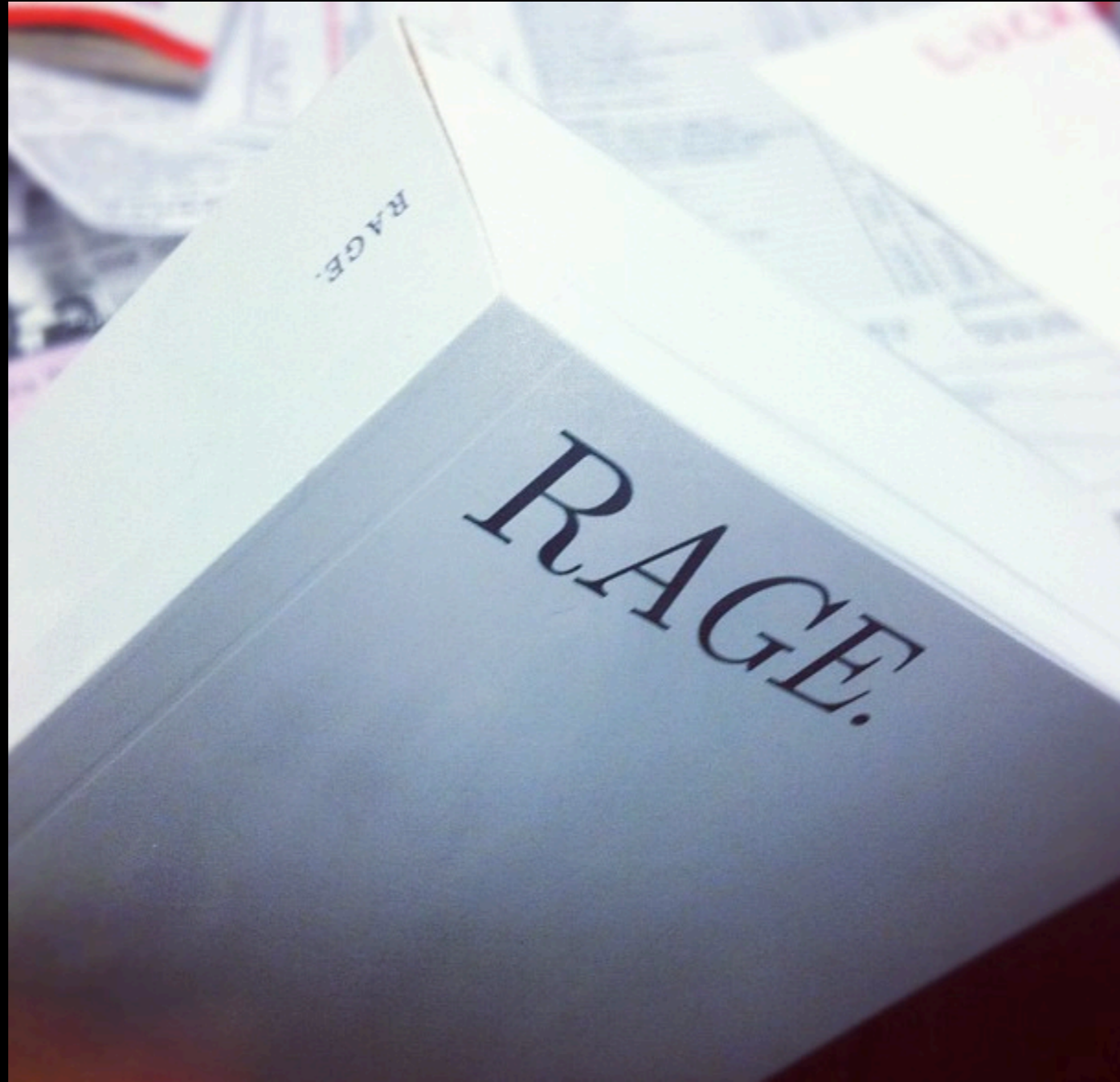

by @johnjannuzzi

OR Books,
2011



TWEETS
from
TAHRIR

Egypt's revolution as
it unfolded, in the
words of the people
who made it

Edited by NADIA IDLE
and ALEX NUNNS

With a foreword by
AHDAF SOUEIF



Sandmonkey Mahmoud Salem
news that Suleiman's been appointed
opposition leaders the demands of protest
amendments.. #Jan25
09:02:39 Feb 1



Sandmonkey Mahmoud Salem
(cont.) these opposition leaders hav nothin
#Jan25
09:04:05 Feb 1



Sandmonkey Mahmoud Salem
same opposition leaders who never made
sizable followin or gain 1 victory or get a
what we have now #Jan25
09:05:19 Feb 1



Sandmonkey Mahmoud Salem
today is the big day :) going out soon. hear
their mothers to join. People getting friends
going. #jan25
09:32:31 Feb 1



Sandmonkey Mahmoud Salem
I hope we do get our million man march today
09:32:48 Feb 1



ashrafkhalil ashraf khali
Jan 25: Tweeting via my lovely wife about
ISP finally shut down last night.
10:47:48 Feb 1



ashrafkhalil ashraf khali
#Jan25: mass numbers expected today - the
Cairo, starting in Tahrir. Call for the people to
to flood the capital.
10:53:44 Feb 1



ashrafkhalil ashraf khali
#Jan25: Mubarak ordered trains to shut down
obvious attempt to limit access to Cairo
10:55:05 Feb 1



ashrafkhalil ashraf khali
#Jan25: Fears that pro-Mubarak rally/thug-squad will try to
spark violence. Protesters completely aware and expecting
this.
10:57:55 Feb 1



Sandmonkey Mahmoud Salem
made it into tahrir. They shut down major entrances & making
it very difficult to get in but thousands & thousands of ppl here
#Jan25
11:55:44 Feb 1





Sandmonkey Mahmoud Salem
We laughed today when we heard that Jordanian king sacked
government preemptively. We're with you people of #Jordan
#Jan25
19:58:23 Feb 1





#Jan25

Photograph by @3arabawy Hossam el-Hamalawy - www.arabawy.org

 **ashrafkhalil** ashraf khalil
#Jan25 7 am and the 1st thing I hear is the west
(illegitimate!) coming through balcony door from
07:22:54 Jan 31

 **ashrafkhalil** ashraf khalil
#jan25 Israel lobbying hard to save Mubarak.
touching... <http://tinyurl.com/5sfhn5j>
09:22:11 Jan 31

 **monasosh** monasosh
Wael Ghonim from Alex, Marketing manager of Google
& activist, no one can trace him since Friday #Jan25
11:48:26 Jan 31

 **3arabawy** Hossam حسام
Police is creeping back to some neighborhoods in
started v late last night. Officers I've seen so far
traffic police.
12:11:21 Jan 31

 **3arabawy** Hossam حسام
The protests in Tahrir yesterday were very strong
more than 100,000 in the square.
12:17:17 Jan 31

 **3arabawy** Hossam حسام
I walked back from Tahrir to Nasr City yesterday
committees. Many shabab with swords said they
they show up.
12:19:09 Jan 31

 **3arabawy** Hossam حسام
More protests r scheduled today in Alexandria, Mansara
other cities. Thousands of protesters r now in Tahrir
Numbers will swell
12:22:13 Jan 31

 **3arabawy** Hossam حسام
The army is protecting police stations that haven't
down. Traffic police officers stay close to army
protection.
12:32:11 Jan 31

 **3arabawy** Hossam حسام
Internet is still blocked on ISPs: TEDATA and Link. I'm using
a satellite connection via a journalist friend now. It's VERY
SLOW however.
12:47:43 Jan 31

 **Gsquare86** Gigi Ibrahim جيجي
I am back for a few..The police is fuckin back on the streets
and WE WILL NOT STOP!!! It is me or them at this point!!
12:47:48 Jan 31

 **Gsquare86** Gigi Ibrahim جيجي
The people are calling for a million-plus people march
tomorrow, which will be marking a week since #Jan25
12:53:30 Jan 31

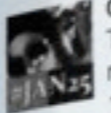
 **Gsquare86** Gigi Ibrahim جيجي
The people have waited 30 years for this, no way will back out
now!! The people or Mubarak in this country!!!
13:21:41 Jan 31

 **3arabawy** Hossam حسام
To our Arab brothers and sisters, if you want to support our
intifada, overthrow your dictators. We need a regional intifada.
13:29:14 Jan 31

 **monasosh** monasosh
I feel I haven't said it recently, FUCK YOU MOBARAK #Jan25
13:39:51 Jan 31

 **3arabawy** Hossam حسام
I spoke with a trade unionist in Suez now. The protests
continue. Popular committees r running security. Police has
vanished.
13:53:59 Jan 31

 **monasosh** monasosh
Important: if u read reports of shotguns heard don't take it
too seriously,we don't even budge when we hear them. We r
really safe! #JAN25
13:57:05 Jan 31

masosh
from Alex, Marketing manager of Google
ne can trace him since Friday #Jan25

عمو حسام حسام
ng back to some neighborhoods in Cairo
st night. Officers I've seen so far r

عمو حسام حسام
Tahrir yesterday were very strong. We
000 in the square.

عمو حسام حسام
om Tahrir to Nasr City yesterday, saw
ny shabab with swords said they'll

عمو حسام حسام
cheduled today in Alexandria, Mada
ousands of protesters r now in Tahrir
ell

 **Gsquare86** Gigi Ibrahim جينيح
I am back for a few. The police is fuckin back on the streets
and WE WILL NOT STOP!!! It is me or them at this point!!
12:47:48 Jan 31

 **Gsquare86** Gigi Ibrahim جينيح
The people are calling for a million-plus people march
tomorrow, which will be marking a week since #Jan25
12:53:30 Jan 31

 **Gsquare86** Gigi Ibrahim جينيح
The people have waited 30 years for this, no way will back out
now!! The people or Mubarak in this country!!!
13:21:41 Jan 31

 **3arabawy** Hossam حسام
To our Arab brothers and sisters, if you want to support our
intifada, overthrow your dictators. We need a regional intifada.
13:29:14 Jan 31

 **monasosh** monasosh
I feel I haven't said it recently, FUCK YOU MOBARAK #Jan25
13:39:51 Jan 31

 **3arabawy** Hossam حسام
I spoke with a trade unionist in Suez now. The protests
continue. Popular committees r running security. Police has
vanished.
13:53:59 Jan 31

 **monasosh** monasosh
Important: if u read reports of shotguns heard don't take it
too seriously we don't even budge when we hear them. We



Spécimens de
fontes libres

L'Ève future

Ascender Corporation
GPL v2 with some exceptions
Création : 2007

Liberation Serif regular 810 pt

encore plus étonné de cette simplicité de leur explication, si je vous la donnais à l'instant, que vous ne l'êtes de leur apparence mystère. – Mais, je vous l'ai dit : dans l'intérêt de l'illusion nécessaire, il me semble utile de différer encore la révélation de ce secret. Et tenez ! – Remarquez-vous une chose bien plus extraordinaire, mon cher lord : c'est que vous ne m'ayez pas questionné sur la nature du visage actuel de l'Andrède ?

¶ Lord Ewald tressaillit. ¶ – Puisqu'il est veillé, dit-il, j'ai pensé qu'il serait peu discret de m'en enquérir. ¶ Edison regarda lord Ewald avec un sourire grave. ¶ – J'imaginai, répondit-il, que vous ne teniez pas à vous créer un souvenir capable de troubler la vision que je vous ai promise : le visage qui vous apparaîtrait ce soir demeurerait fixé en votre mémoire et transparaîtrait toujours pour vous sous le visage futur qui, seul, est votre espérance. Et ce souvenir gênerait votre illusion en éveillant sans cesse une arrière-pensée de dualité. C'est pourquoi, même si ce voile cachait le visage d'une Béatrix idéalée, vous ne tenez pas à le voir – et vous avez raison. C'est aussi pour un motif analogue que je ne puis vous révéler, aujourd'hui, le secret dont vous parlez. ¶ – Soit, répondit lord Ewald. ¶ Puis, comme voulant dissiper l'idée suscitée par l'électricien : ¶ – Vous allez donc revêtir Hadaly, reprit-

Liberation Serif regular
Liberation Serif italic
Liberation Serif bold
Liberation Serif bold italic

a b c d e f g
h i j k l m n
o p q r s t u
v w x y z A
B C D E F G
H I J K L M
N O P Q R S
T U V W X Y
Z 1 2 3 4 5
6 7 8 9 0 . ,
: ; ! / & @ # \$ %
^ & # \$ % ^ &

Liberation Serif regular 1215 pt

les coagulant d'une façon homogène (comme la Vie pétrit les éléments de notre chair), a littéralement transfiguré leur individualité en une synthèse qui ne s'analyse pas, mais qui se ressent. ¶ Vous ne sauriez imaginer jusqu'à quel point tenez, l'impalpable poudre de fer réduit, aimanté, disséminé à l'état blanc, en cette

Liberation Serif regular 1417 pt

Carnation, la rend sensible à l'action électrique. Les capillaires extrémités des fils d'induction qui traversent les jours imperceptibles de l'armure sont mêlées aux fibreuses applications de cette chair, – à laquelle la membrane diaphane de l'Épiderme,

Liberation Serif

noissardra, l'expression
étincelle
notre
parfumée
mélodieuse
chante
âme
lueur
fausse-fleur
m
cigare
calorique
allumer
fluide
inoffensive
masio
parfumée
mélodieuse
chante
âme
lueur
fausse-fleur
m

de l'expression de l'âme à l'âme
est que de l'expression, sans pouvoir
allumer sans chaleur à cette étincelle
suffisante, dans cette même flamme
pour profane et chaude, pour
sublime, l'âme de cet instant.



Day1

Day2

Day3

day4

Communication



Handwritten notes on a whiteboard.



L'Eve future - Specimens de fontes libres: Un guide typographique open-source (French Edition) Paperback

by [Manuel Schmalstieg](#) (Author) , [Patricio André](#) (Designer) & 11 more

[Be the first to review this item](#)

Paperback

\$18.00

[2 New from \\$18.00](#)

Les fontes libres et open-source affichent depuis quelques années une grande vitalité, notamment suite à leur entrée dans les navigateurs Web et l'apparition de services en ligne comme Google Webfonts. La grande variété de ces fontes fut le déclencheur de ce livre, élaboré lors d'un workshop à la HEAD (Haute école d'art et de design – Genève) en février 2013. Réalisé par des étudiants de la filière Communication visuelle, ce livre présente plus de deux cents spécimens de fontes libres, permettant d'examiner et de comparer leurs caractéristiques pour différents corps de texte. S'il est en premier lieu un [Read more](#)

#pod #spam

alphascript publishing



Frederic P. Miller, Agnes F. Vandome, John
McBrewster (Hrsg.)

K Foundation Burn a Million Quid

K Foundation, Bill Drummond, Jimmy Cauty, Burning money,
Pound sterling, Jura, Scotland, The KLF, Alan Goodrick
(Award), Fuck the Millennium (Taschenbuch)



 **VERGRÖßERN**

[Größeres Bild \(mit Zoom\)](#)

[Für Kunden: Stellen Sie Ihre eigenen Bilder ein.](#)

[Verleger: So können Kunden in diesem Buch suchen.](#)

K Foundation Burn a Million Quid: K Foundation, Bill Drummond, Jimmy Cauty, Burning money, Pound sterling, Jura, Scotland, The KLF, Alan Goodrick ... K Foundation art award, Fuck the Millennium (Taschenbuch)

von [Frederic P. Miller](#) (Herausgeber), [Agnes F. Vandome](#) (Herausgeber), [John McBrewster](#) (Herausgeber)

Noch keine Kundenrezensionen vorhanden: [Schreiben Sie die erste!](#)

Preis: **EUR 34,00** **Kostenlose Lieferung.** [Siehe Details.](#)

Auf Lager.

Verkauf und Versand durch **Amazon.de**. Geschenkverpackung verfügbar.

Lieferung bis Montag, 25. Januar: Bestellen Sie in den nächsten 15 Stunden und 46 Minuten per **Overnight-Express.** [Siehe Details.](#)

Produktinformation

Taschenbuch: 100 Seiten

Verlag: Alphascript Publishing (8. Dezember 2009)

Sprache: Englisch

ISBN-10: 6130245858

ISBN-13: 978-6130245856

K Foundation Burn a Million Quid: K Foundation, Bill Drummond, Jimmy Cauty, Burning money, Pound sterling, Jura, Scotland, The KLF, Alan Goodrick ... K Foundation art award, Fuck the Millennium

Frederic P. Miller, Agnes F. Vandome, John
McBrewster (Ed.)

K Foundation Burn a Million Quid

ation, Bill Drummond, Jimmy Cauty, Burning money,
ound sterling, Jura, Scotland, The KLF, Alan Goodrick
, Doctorin' the Tardis, K Foundation art award, Fuck
the Millennium



1.



All Star Batman and Robin the Boy Wonder: Comic book, Frank Miller (comics), Jim Lee, DC Comics, All Star DC Comics, Imprint, DC Universe, Continuity (fiction), Setting (fiction) by Frederic P. Miller, Agnes F. Vandome, and John McBrewster (**Paperback** - Dec 8, 2009)

[Buy new:](#) ~~\$43.00~~

Get it by **Monday, Jan 25** if you order in the next **15 hours** and choose one-day shipping.

Eligible for **FREE** Super Saver Shipping.

★★★★☆ (7)

Other Editions: [Paperback](#), [Library Binding](#)

2.



Marketing Effectiveness: Marketing effectiveness, Go to market, Marketing performance measurement and management, Return on marketing investment, Marketing, ... Marketing mix, Marketing mix modeling by Frederic P. Miller, Agnes F. Vandome, and John McBrewster (**Paperback** - Dec 9, 2009)

[Buy new:](#) ~~\$50.00~~ **\$39.21**

Get it by **Monday, Jan 25** if you order in the next **15 hours** and choose one-day shipping.

Eligible for **FREE** Super Saver Shipping.

3.



Algae fuel: Biofuel, Algae, Algaculture, Vegetable fats and oils, Biodiesel, Biogasoline, Methanol fuel, Butanol fuel, Biodegradation, Soybean, Aquatic ... Seaweed, Botryococcus braunii, Chlorella by John McBrewster, Frederic P. Miller, and Agnes F. Vandome (**Paperback** - May 20, 2009)

[Buy new:](#) ~~\$67.00~~ **\$52.20**

[2 new](#) from **\$52.20** [1 used](#) from **\$84.73**

Get it by **Monday, Jan 25** if you order in the next **15 hours** and choose one-day shipping.

Eligible for **FREE** Super Saver Shipping.

4.



Chilean War of Independence: Criollo people, Spanish Empire, Chiloé Archipelago, Chilean Declaration of Independence. Hispanic American wars of independence. Patria

@alphascript publishing



Frederic P. Miller, Agnes F. Vandome,
John McBrewster (Ed.)

History of Georgia (country)

Colchis, Mongol invasions of Georgia and Armenia, Timur
invasions of Georgia, Georgia within the Russian Empire,
Democratic Republic of Georgia, Caucasian Iberia, Tao-Klarjeti

 ZOOM

[See larger image \(with zoom\)](#)

[Share your own customer images](#)

[Publisher: learn how customers can search
inside this book.](#)

History of Georgia (country): Colchis, Mongol invasions of Georgia and Armenia, Timurs invasions of Georgia, Georgia within the Russian Empire, Democratic ... of Georgia, Caucasian Iberia, Tao-Klarjeti (Paperback)

~ [John McBrewster](#) (Editor), [Frederic P. Miller](#) (Editor), [Agnes F. Vandome](#) (Editor)

★ ★ ☆ ☆ ☆ [\(4 customer reviews\)](#)

Price: **\$77.00** & this item ships for **FREE with Super Saver Shipping.**

[Details](#)

In Stock.

Ships from and sold by **Amazon.com**. Gift-wrap available.

Want it delivered Monday, January 25? Order it in the next 15 hours and 18 minutes, and choose **One-Day Shipping** at checkout. [Details](#)

2 new from **\$77.00**

History of Georgia (country): Colchis, Mongol invasions of Georgia and Armenia, Timurs
invasions of Georgia, Georgia within the Russian Empire, Democratic ... of Georgia, Caucasian
Iberia, Tao-Klarjeti

@lphascript publishing



Frederic P. Miller, Agnes F. Vandome,
John McBrewster (Ed.)

History of Georgia (country)

Colchis, Mongol invasions of Georgia and Armenia, Timurs
invasions of Georgia, Georgia within the Russian Empire,
Democratic Republic of Georgia, Caucasian Iberia, Tao-Klarjeti

When a book has the wrong image for the cover, you know this is a big indication that something is wrong.

LEK

LEKAR, LEKSAKER, SPEL, SPELKORT, JACKPOTT, MECCANO, ALTERNATE REALITY GAME, TENNFIGUR, BEYBLADE, STEN, SAX, PÅSE, LEGO EXO-FORCE, JOJO, BILLEK, KURRAGÖMMA, STUDSMATTA, DINO-RIDERS, BRÄDE, SPELKULA, ÖLLEVERANSSPELET, HELLO KITTY, BUSRINGNING



[See larger image](#)

[Share your own customer images](#)

[Publisher: learn how customers can search inside this book.](#)

Lek: Lekar, Leksaker, Spel, Spelkort, Jackpott, Meccano, Alternate reality game, Tennfigur, Beyblade, Sten, sax, påse, Lego Exo-force, Jojo (Swedish Edition) [Paperback]

Källa: [Wikipedia](#) (Author)

[Be the first to review this item](#) |  Like (0)

Price: **\$19.99** & eligible for **FREE Super Saver Shipping** on orders over \$25

[Details](#)

In Stock.

Shipping this item to your default address may require an additional 2 to 3 weeks process.

Ships from and sold by **Amazon.com**. Gift-wrap available.

5 new from \$19.98 **1 used** from \$21.73

Book Description

Publication Date: **September 4, 2011**

Källa: Wikipedia. Sidor: 91. Kapitlen: Lekar, Leksaker, Spel, Spelkort, Jackpott, Meccano, Alternate reality game, Tennfigur, Exo-force, Jojo, Billek, Kurragömma, Studsmatta, Dino-Riders, Bräde, Spelkula, Ölleveransspelet, Hello Kitty, Busringning, betting, Hopprep, Badanka, Transformers, Monchhichi, Ruta, Matrjosjka, Hela havet stormar, Lekplats, Slantsingling, Drak, Brännboll, Skoträd, Äggrullning, Six degrees of Kevin Bacon, Tafatt, Docka, Potatiskanon, Anden i glaset, Arga leken, Kuls, Pussel, Kinderägg, Röda lyktan stopp, Bratz, Amigurumi, Tvärtomspråket, Snurra, Nallebjörn, Såpbubbla, Slå katten ur tur, Fingerboard, Mobile Station, Russinleken, Kancho, Snöbollskrig, Badleksak, Pulka, Parklek, Hoppa hage, Hänga gubbe, Ho, Koja, Morra, Ryska posten, Hobbyångmaskin, NE-spelet, Kalejdoskop, Leksandlåda, Bilderbok, Pappersloppa, Nendoroid, C, Jullekar, Femtonspel, The Game, Käpphäst, Lekrum, Åkmadrass, Viskleken, Playmobil, Klippdocka, Kålungar, Skrållan, Fru, Bindeez, Räkneramsor, Flagg, Furby, Vasshått, I-språket, Kramdiur, Jägarboll, Platespotting, Påven bannlyser, Kuddkrig, K

Search Over 30 Million Products

All Products

Search

Shopping Bag (0 items)

Spend \$25, Get FREE SHIPPING



Books | NOOK Books | **nook** | Textbooks | Newsstand | Teens | Kids | Toys & Games | DVDs | Home & Gifts | Electronics | Gift Cards

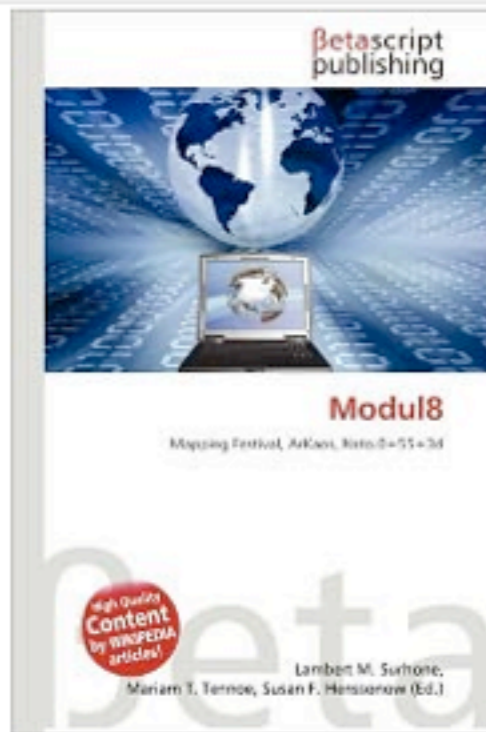

Modul8

by Lambert M. Surhone, Mariam T. Tennoe (Editor), Susan F. Henssonow (Editor)

★★★★☆ Be the first to write a review

Add to List +

Paperback

\$68

BN.com price

Usually ships within 24 hours [details](#)

Add to Bag

Marketplace (New and Used)

from

\$66.88

~~\$68.00~~ List Price (Save 2%)

Usually ships within 1-2 business days

New (1) ▾

Used (1) ▾

All (2) ▾

Overview

High Quality Content by WIKIPEDIA articles! Modul8 is a software for live visual performance developed by GarageCube, a company established in 2005 by Yves Schmid and Boris Edelstein, based in Geneva, Switzerland. Modul8 was started with the intention of providing a tool for VJing in OpenGL. The first public release was in 2004, followed by version 2 in 2005. While the first version was a stripped down real-time compositing environment, the second version introduced a module system, allowing customization of the software interface. Modul8 also offers support for multiple screen output on the MacPro. The application also has an integrated programming environment that allows to write Python scripts inside the application.

...

[See more details below](#)

Search Books:

By Keyword 

Find Book

[Home](#) > > [Novels By Jerry Pournelle, including: The Legacy Of Heorot, The ...](#)



[View Larger Image](#)

Novels By Jerry Pournelle, including: The Legacy Of Heorot, The Mote In God's Eye, The Gripping Hand, Footfall, Inferno (novel), Fallen Angels (scienc

(ISBN 10: [1242814744](#) / ISBN 13: [9781242814747](#))

Bookseller: SuperBookDeals (South Bend, IN, U.S.A.)

Bookseller Rating: ★★★★★

Quantity Available: 10

[Print on Demand](#)

About the Book

[Bookseller & Payment Information](#)

Description:

This item is printed on demand. Bookseller Inventory # 13174583-n

About the Book

[Bookseller & Payment Information](#)



Price:

[Convert C](#)

Shipping

From U.S.

[Destinati](#)

[30 Day R](#)

Bibliogr

Title: **No**

Pournel

Book Co

types of #spam

#algorithmic

#spam

The 2009 Economic and Product Market Databook for Bangkok, Thailand



by
Professor Philip M. Parker, Ph.D.
Chaired Professor of Management Science
INSEAD (Singapore and Fontainebleau, France)

The 2009 Economic and Product Market Databook for Bangkok, Thailand Paperback

by [Icon Group International](#) (Author)

[Be the first to review this item](#)

Paperback

\$71.21

1 New from **\$71.21**

In performing various economic analyses for its clients, I have occasionally been asked to investigate the market potential for various products and services in Thailand. The purpose of this study is to understand the density of demand within Thailand and the extent to which Bangkok might be used as a point of distribution within Asia. From an economic perspective, however, Bangkok does not represent a population within rigid geographical boundaries, rather, it represents an area of dominant influence over markets in adjacent areas. This influence varies from one industry to another, but also

▼ [Read more](#)

The 2013 World Forecasts of
Artificial Guts (Sausage Casings)
Made of Hardened Protein or
Cellulosic Materials Export Supplies



by
Professor Philip M. Parker, Ph.D.
Chaired Professor of Management Science
INSEAD (Singapore and Fontainebleau, France)

[Click to open expanded view](#)

The 2013 World Forecasts of Artificial Guts (Sausage Casings) Made of Hardened Protein or Cellulosic Materials Export Supplies [Paperback]

[Icon Group International](#) (Author)

[Be the first to review this item](#)

Price: **\$325.00** & **FREE Shipping**. [Details](#)

In Stock.

Ships from and sold by **Amazon.com**. Gift-wrap available.

Want it tomorrow, Oct. 25? Order within **6 hrs 53 mins** and choose **One-Day Shipping** at checkout. [Details](#)

[Share](#)    

Books › **"icon group international"**

Showing 1 - 12 of 875,267 Results



Detail



Image

#human-made

#spam

NEWS

ABOUT US

SERVICE WE PROVIDE
FOR YOU

PARTNERS

LOCATION





nu trop bon !!!!

Alphascript Editor – ASP

 Join

Wall

Info

Discussions

Photos

Video

Events

Basic Info

Name:

Alphascript Editor – ASP

Category:

Business – Companies

Description:

Alphascript publishing publishes academic research worldwide – at no cost to our authors.

Annually, we publish more than 10,000 new titles and are thus one of the leading publishing houses of academic research. We specialize in publishing copyleft projects.



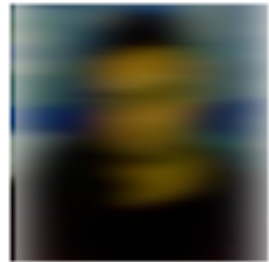

██████████ Good work dear Editors !!! 11,774 !! Respect guys !!!

April 1 at 5:11pm · [Comment](#) · [Like](#) · [Report](#)



██████████ likes this.

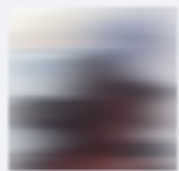

██████████ C'est vrai sa on est trop bon et sa va continuer nou bizin enterre bane moldave vivant dans un futur tres proche ;)

April 1 at 5:15pm · [Report](#)

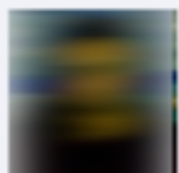

██████████ haha ! ta raison ! ta tjour raison ! LOL ! g fai 400 ce mois ci

April 1 at 5:19pm · [Report](#)

Employer:

████████████████████

Position:

VTT Transcription Agent

Time Period:

████████████████████

Location:

Rose Hill, Mauritius

Description:

We listen to voicemails and then convert it to text messages.

Christey

Informational

RFC 2795

The Infinite Monkey Protocol Suite (IMPS)

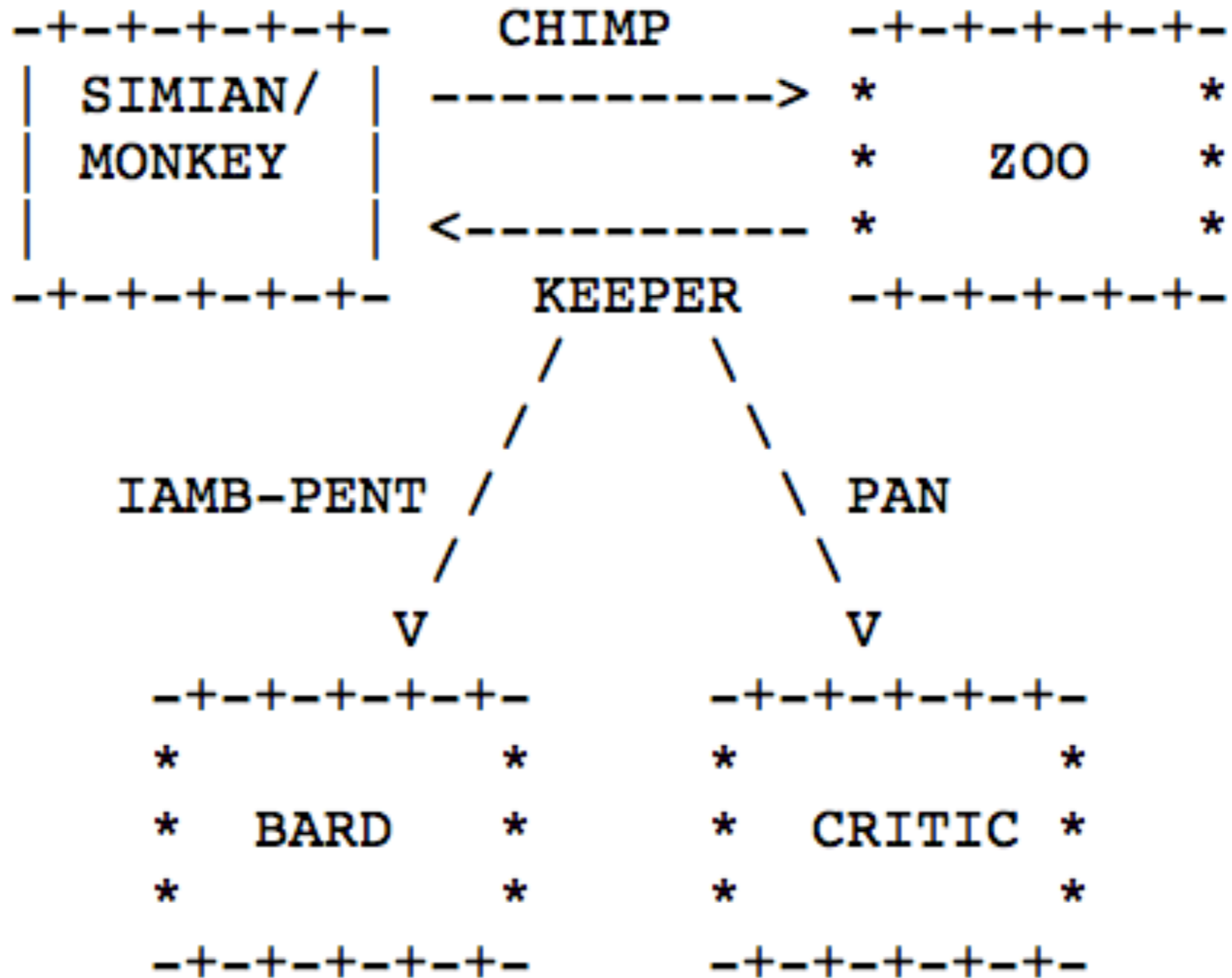

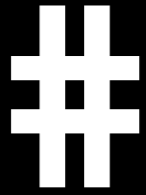

#academic pub.



Letters, Postcards, Email

Technologies of Presence

By **Esther Milne**

Published February 3rd 2010 by Routledge – 262 pages

Series: [Routledge Research in Cultural and Media Studies](#)

 View Inside this Book

 e-Inspection Copy

 Recommend to Librarian

Description

Contents

Author Bio

Subjects

In this original study, Milne moves between close readings of letters, postcards and emails, and investigations of the material, technological infrastructures of these forms, to answer the question: How does presence function as an aesthetic and rhetorical strategy within networked communication practices? As her work reveals, the relation between old and new communication systems is more complex than allowed in much contemporary media theory.

Although the correspondents of letters, postcards and emails are not, usually, present to one another as they write and read their exchanges, this does not necessarily inhibit affective communication. Indeed, this study demonstrates how physical absence may, in some instances, provide correspondents with intense intimacy and a spiritual, almost telepathic, sense of the other's presence. While corresponding by letter, postcard or email, readers construe an imaginary, incorporeal body for their correspondents that, in turn, reworks their interlocutor's self-presentation. In this regard the fantasy of presence reveals a key paradox of cultural communication, namely that material signifiers can be used to produce the

Purchasing Options:

Hardback: 978-0-415-99328-9: \$

 Add to Cart

eBook: 978-0-203-86215-5:

 Order from T&F eBookStore



 Tweet 9

 Like

 3 people like this. Be the first to like this.

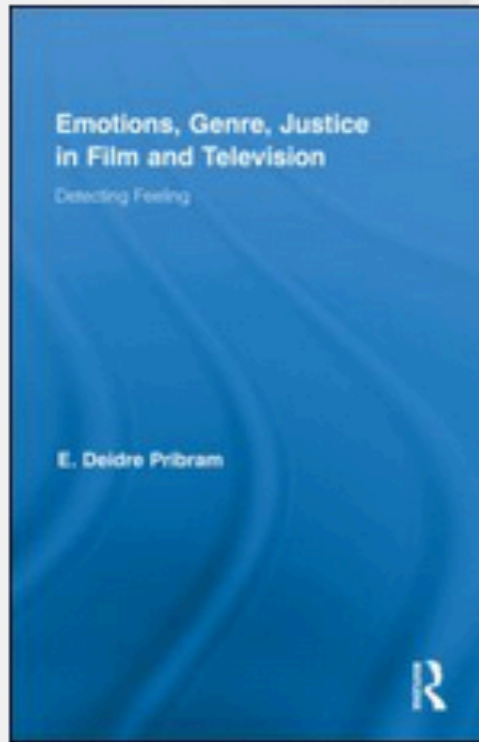

New in Paperback

Emotions, Genre, Justice in Film and Television

Detecting Feeling

By **Deidre Pribram**

Routledge – 2011 – 148 pages

Series: [Routledge Research in Cultural and Media Studies](#)[View Inside this Book](#)[e-Inspection Copy](#)

Description

[Reviews](#)[Contents](#)[Author Bio](#)[Subjects](#)

Purchasing Options:

Paperback: \$44.95

978-0-415-84736-0

October 14th 2013

Hardback: \$140.00

978-0-415-99828-4

April 25th 2011

[eBook Ordering Options](#)

Popular film and television are ideally suited in understanding how emotions create culturally shared meanings. Yet very little has been done in this area. *Emotion, Genre, and Justice in Film and Television* explores textual representations of emotions from a cultural perspective, rather than in biological or psychological terms. It considers emotions as structures of feeling that are collectively shared and historically developed.

Through their cultural meanings and uses, emotions enable social identities to be created and contested, to become fixed or alter. Popular narratives often take on emotional significance, aiding groups of people in recognizing or expressing what they feel and who they are. This book focuses on the justice genres – the generic network of film and television programs that are concerned with crime, law, and social order – to examine how fictional police, detective, and legal stories participate in collectively realized conceptions of emotion. A range of films (*Crash*, *Man on Fire*) and television series (*Cold Case*, *Cagney and Lacey*) serve as case studies to explore contemporarily relevant representations of anger, fear, loss and consolation, and



#academic pub.

#cc-by-sa

Article Sources and Contributors

Gold Coast (British colony) Source: [http://en.wikipedia.org/w/index.php?title=Gold Coast %28British colony%29](http://en.wikipedia.org/w/index.php?title=Gold_Coast_%28British_colony%29) Contributors: Ahanta, Amire80, Ante Perkovic, BLOGuil, BenKilb23, BigCow, Bynms, Bobblehead, Bornintheguz, CJ, CalJW, Chris the speller, Cobaltbluetony, Colibri37, Ctande, Darwinek, DavidWBrooks, Davidley, Diverman, Edward, Epolk, Gaz, Greenman, Harryboyles, Henrygb, Hugo.arg, Hugo999, Idera, J.delanoy, Jackyd101, Joaopais, Joseph Solis in Australia, Kaare, Keraunos, Kintetsubuffalo, Kowtoo, Leandro, Lightmouse, Lilac Soul, Lofty, Lupo, Mangostar, Matthew Stannard, Matisse, Meredyth, Mic, Mild Bill Hiicup, Mosca, Nareek, Neddysagoon, Nedrutland, Orioane, Parsa, Petepetepete, Picaroon, Puuropysy, Qllach, Quillercouch, Ranveig, Roke, SelfQ, Shattered Gnome, SimonArlott, SimonP, Starbestommy, Suidafrikaan, The Ogre, Tkynerd, Van helsing, Verne Equinox, Warofdreams, Whyteocypress, XYZ CrVo, Yuntila, Zigger, Zscout370, 63 anonymous edits

History of Ghana (1966-1979) Source: [http://en.wikipedia.org/w/index.php?title=History of Ghana %281966-1979%29](http://en.wikipedia.org/w/index.php?title=History_of_Ghana_%281966-1979%29) Contributors: Edgepedia, Excirial, MBisanz, Mangostar, 1 anonymous edits

Elmina Castle Source: [http://en.wikipedia.org/w/index.php?title=Elmina Castle](http://en.wikipedia.org/w/index.php?title=Elmina_Castle) Contributors: -1g, Aanderson@amberst.edu, Ahanta, Akuajennifer, Awakened crowe, Bobblehead, Bobo192, Bookandcoffee, Bporter615, Caerwine, CuandoCubango, Davidley, Delpino, Doortmont, Falconry, Fastifex, Firsfron, Gaius Cornelius, Graham87, Grutness, Gullacum, HanClinto, Hide&Reason, Hugo999, Indon, JForget, Lewisskinner, Manuel de Sousa, Mark Dingemans, Mindmatrix, Natsubee, Neik, Pharaoh of the Wizards, Portuguez, Pslandau, Rjwilmsi, Rotte Goldfish Mazet, S, Serte, Steevo714, The Ogre, Thomas.macmillan, Verne Equinox, Warofdreams, XPTO, 40 anonymous edits

Ghana Empire Source: [http://en.wikipedia.org/w/index.php?title=Ghana Empire](http://en.wikipedia.org/w/index.php?title=Ghana_Empire) Contributors: 4shizzal, Alansohn, AlecTrevelyan402, Collounsbury, Epbr123, Erik9, J.delanoy, Kh3rd, Kmemia Maina, Kingpin13, Malig123, Mentifisto, Neverquick, Nishkid64, RekishiEJ, RexNL, SimonP, Synchronism, Taharqa, 59 anonymous edits

Ashanti Empire Source: [http://en.wikipedia.org/w/index.php?title=Ashanti Empire](http://en.wikipedia.org/w/index.php?title=Ashanti_Empire) Contributors: 4shizzal, Absurdist, Ashoroman, Aymatth2, Barkeep, Barticus88, Blambloom, CanisRufus, Cenarium, Cjrother, Dekimasu, Dimadick, Domino theory, Doortmont, Emmanuel numapau, Enriquecardova, Floaterfluss, Gsandi, Gscshoyru, Hughcharlesparker, Hugo999, Idwanatnum, Iridescent, J04n, Jac16888, Jourdy288, Jurema Oliveira, Kowtoo, Kusunose, Kwame123, Kwame1234, Leithp, Lightmouse, Madman, Mauicelt, Nanuck, Oseirus, QueenCake, RANDY2007, Rjwilmsi, Ruakh, Sesel, Silly rabbit, SimonP, Taharqa, TakaraLioness, Timeshifter, Truthwillprevail12, Yamara, Yellowliver, Yom, Zykasaa, 116 anonymous edits

Anglo-Ashanti wars Source: [http://en.wikipedia.org/w/index.php?title=Anglo-Ashanti wars](http://en.wikipedia.org/w/index.php?title=Anglo-Ashanti_wars) Contributors: 4shizzal, A new name 2008, Bobjenkins831, Bpmullins, Drunkenlogger, Enriquecardova, Feydey, Hemlock Martinis, Hugo999, Jaraalbe, Kernel Saunters, Lomis, Motacilla, Mr Adequate, Norm mit, Wikiashes, Yellowliver, 4 anonymous edits

John Kufuor Source: [http://en.wikipedia.org/w/index.php?title=John Kufuor](http://en.wikipedia.org/w/index.php?title=John_Kufuor) Contributors: (:Julien:), -js-, 4shizzal, Abqy, Academic Challenger, Ace ETP, Acntx, Alexius08, Andy120290, ArielGold, Ash Rust, Barkund, Barneca, Bash, Birutorul, CCorward, Camelcast, Captain-tucker, CarlKenner, Cmc0, Cnyborg, Colonies Chris, Craigy144, D6, Dantadd, Darwinek, Davidley, Descendall, Deville, Discospinster, Editorofthewiki, Epbr123, Everyking, Evleki, Faddamike, Good Olfactory, Grendelkhan, Ground, Haddiscoe, HennessyC, Homagetocatalonia, Huangdi, iamwisesun, Ian Pitchford, JamesR, Jiang, Jj137, Jockson2468, Jose77, Joseph Solis in Australia, Jpeob, Kappa, Khukri, Kingka, Kschwerdt514, Kwekubo, Lincolnite, Madamebovary, Marc-André Abbrock, Morwen, Nakos2208, Natsubee, Nicke Lilltroll, No1lakersfan, Normalityrelief, OrangeCounty39, Pawel ze Szczecina, Pir, Quadell, Qwm, Revth, Richidgh, Rocastelo, Rschen7754, Russavia, Samaritan, Sardanaphalus, Scanlan, Sesel, Slakr, Sliggy, SteinbDJ, THB, Tenmei, The Singing Badger, Therequiembellishere, Tomlillis, Toussaint, TwinsFan48, Ybbor, 100 anonymous edits

Osei Kofi Tutu I Source: [http://en.wikipedia.org/w/index.php?title=Osei Kofi Tutu I](http://en.wikipedia.org/w/index.php?title=Osei_Kofi_Tutu_I) Contributors: Ahanta, AnnaFrance, Buddhist Monk Wannabe, Chris the speller, Cleared as filed, Jackyd101, Jaraalbe, Kwame1234, Nishkid64, Ntsimp, Numbo3, Sannse, SimonP, The Singing Badger, 14 anonymous edits

Kofi Abrefa Busia Source: [http://en.wikipedia.org/w/index.php?title=Kofi Abrefa Busia](http://en.wikipedia.org/w/index.php?title=Kofi_Abrefa_Busia) Contributors: Acntx, Beaunic, Birutorul, Biscuit tech, Chris the speller, Cmdrjameson, Colonies Chris, Good Olfactory, Hbackman, Kenguest, Natsubee, Oxonian2006, Pearle, Pietro morrizio, RjFJR, Sam Hocevar, Sesel, SteinbDJ, 13 anonymous edits

Ignatius Kutu Acheampong Source: [http://en.wikipedia.org/w/index.php?title=Ignatius Kutu Acheampong](http://en.wikipedia.org/w/index.php?title=Ignatius_Kutu_Acheampong) Contributors: Academic Challenger, Chicheley, Darwinek, David Kernow, Davidley, Dvyost, Faddamike, Fenice, Good Olfactory, Guntherloppy, KazakhPol, Kschwerdt514, Kwekubo, Magnet For Knowledge, Marc Mongenet, Martin H., Michael David, Natsubee, Neutrality, Pietro morrizio, Pir, RickK, Rjwilmsi, Sesel, Siroxo, Sliggy, Stefanomione, 18 anonymous edits

GNU Free Documentation License Version 1.2
November 2002 Copyright (C) 2000,2001,2002
Free Software Foundation, Inc. 59 Temple
Place, Suite 330, Boston, MA 02111-1307 USA
Everyone is permitted to copy and distribute
verbatim copies of this license document, but
changing it is not allowed.

0. PREAMBLE

The purpose of this License is to make a manual, textbook, or other functional and useful document "free" in the sense of freedom: to assure everyone the effective freedom to copy and redistribute it, with or without modifying it, either commercially or noncommercially. Secondly, this License preserves for the author and publisher a way to get credit for their work, while not being considered responsible for modifications made by others. This License is a kind of "copyleft", which means that derivative works of the document must themselves be free in the same sense. It complements the GNU General Public License, which is a copyleft license designed for free software. We have designed this License in order to use it for manuals for free software, because free software needs free documentation: a free program should come with manuals providing the same freedoms that the software does. But this License is not limited to software manuals; it can be used for any textual work, regardless of subject matter or whether it is published as a printed book. We recommend this License principally for works whose purpose is instruction or reference.

1. APPLICABILITY AND DEFINITIONS

This License applies to any manual or other work, in any medium, that contains a notice placed by the copyright holder saying it can be distributed under the terms of this License. Such a notice grants a world-wide, royalty-free license, unlimited in duration, to use that work under the conditions stated herein. The "Document", below, refers to any such manual or work. Any member of the public is a licensee, and is addressed as "you". You accept the license if you copy, modify or distribute the work in a way requiring permission under copyright law. A "Modified Version" of the Document means any work containing the Document or a portion of it, either copied verbatim, or with modifications and/or translated into another language. A "Secondary Section" is a named appendix or a front-matter section of the Document that deals exclusively with the relationship of the publishers or authors of the Document to the Document's overall subject (or to related matters) and contains nothing that could fall directly within that overall subject. (Thus, if the Document is in part a textbook of mathematics, a Secondary Section may not explain any mathematics.) The relationship could be a matter of historical connection with the subject or with related matters, or of legal, commercial, philosophical, ethical or political position regarding them. The "Invariant Sections" are certain Secondary Sections whose titles are designated, as being those of Invariant Sections, in the notice that says that the Document is released under this License. If a section does not fit the above definition of Secondary then it is not allowed to be designated as Invariant. The Document may contain zero Invariant Sections. If the Document does not identify any Invariant Sections then there are none. The "Cover Texts" are certain short passages of text that are listed, as Front-Cover Texts or Back-Cover Texts, in the notice that says that the Document is released under this License. A Front-Cover Text may be at most 5 words, and a Back-Cover Text may be at most 25 words. A "Transparent" copy of the Document means a machine-readable copy, represented in a format whose specification is available to the general public, that is suitable for revising the document straightforwards with generic text editors or (for images composed of pixels) generic paint programs or (for drawings) some widely available drawing editor, and that is suitable for input to text formatters or for automatic translation to a variety of formats suitable for input to text formatters. A copy made in an otherwise Transparent file format whose markup, or absence of markup, has been arranged to thwart or discourage subsequent modification by readers is not Transparent. An image format is not Transparent if used for any substantial amount of text. A copy that is not "Transparent" is called "Opaque". Examples of suitable formats for Transparent copies include plain ASCII without markup, Texinfo input format, LaTeX input format, SGML or XML, using a publicly available DTD, and standard-conforming simple HTML, PostScript or PDF designed for human modification. Examples of transparent image formats include PNG, XCF and JPG. Opaque formats include proprietary formats that can be read and edited only by proprietary word processors, SGML or XML, for which the DTD and/or processing tools are not generally available, and the machine-generated HTML, PostScript or PDF produced by some word processors for output purposes only. The "Title Page" means, for a printed book, the title page itself, plus such following pages as are needed to hold, legibly, the material this License requires to appear in the title page. For works in formats which do not have any title page as such, "Title Page" means the text near the most prominent appearance of the work's title, preceding the beginning of the body of the text. A section "Entitled XYZ" means a named subunit of the Document whose title either is precisely XYZ or contains XYZ in parentheses following text that translates XYZ in another language. (Here XYZ stands for a specific section name mentioned below, such as "Acknowledgements", "Dedications", "Endorsements", or "History".) To "Preserve the Title" of such a section when you modify the Document means that it remains a section "Entitled XYZ" according to this definition. The Document may include Warranty Disclaimers next to the notice which states that this License applies to the Document. These Warranty Disclaimers are considered to be included by reference in this License, but only as regards disclaiming warranties; any other implication that these Warranty Disclaimers may have is void and has no effect on the meaning of this License.

2. VERBATIM COPYING

You may copy and distribute the Document in any medium, either commercially or noncommercially, provided that this License, the copyright notices, and the license notice saying this

License applies to the Document are reproduced in all copies, and that you add no other conditions whatsoever to those of this License. You may not use technical measures to obstruct or control the reading or further copying of the copies you make or distribute. However, you may accept compensation in exchange for copies. If you distribute a large enough number of copies you must also follow the conditions in section 3. You may also lend copies, under the same conditions stated above, and you may publicly display copies.

3. COPYING IN QUANTITY

If you publish printed copies (or copies in media that commonly have printed covers) of the Document, numbering more than 100, and the Document's license notice requires Cover Texts, you must enclose the copies in covers that carry, clearly and legibly, all these Cover Texts: Front-Cover Texts on the front cover, and Back-Cover Texts on the back cover. Both covers must also clearly and legibly identify you as the publisher of these copies. The front cover must present the full title with all words of the title equally prominent and visible. You may add other material on the covers in addition. Copying with changes limited to the covers, as long as they preserve the title of the Document and satisfy these conditions, can be treated as verbatim copying in other respects. If the required texts for either cover are too voluminous to fit legibly, you should put the first ones listed (as many as fit reasonably) on the actual cover, and continue the rest onto adjacent pages. If you publish or distribute Opaque copies of the Document numbering more than 100, you must either include a machine-readable Transparent copy along with each Opaque copy, or state in or with each Opaque copy a computer-network location from which the general network-using public has access to download using public-standard network protocols a complete Transparent copy of the Document, free of added material. If you use the latter option, you must take reasonable prudent steps, when you begin distribution of Opaque copies in quantity, to ensure that the Transparent copy will remain thus accessible at the stated location until at least one year after the last time you distribute an Opaque copy (directly or through your agents or retailers) of that edition to the public. If it is requested, but not required, that you contact the authors of the Document well before redistributing any large number of copies, to give them a chance to provide you with an updated version of the Document.

4. MODIFICATIONS

You may copy and distribute a Modified Version of the Document under the conditions of sections 2 and 3 above, provided that you release the Modified Version under precisely this License, with the Modified Version filling the role of the Document, thus licensing distribution and modification of the Modified Version to whoever possesses a copy of it. In addition, you must do these things in the Modified Version: A. Use in the Title Page (and on the covers, if any) a title distinct from that of the Document, and from those of previous versions (which should, if there were any, be listed in the History section of the Document). You may use the same title as a previous version if the original publisher of that version gives permission. B. List on the Title Page, as authors, one or more persons or entities responsible for authorship of the modifications in the Modified Version, together with at least five of the principal authors of the Document (all of its principal authors, if it has fewer than five), unless they release you from this requirement. C. State on the Title page the name of the publisher of the Modified Version, as the publisher. D. Preserve all the copyright notices of the Document. E. Add an appropriate copyright notice for your modifications adjacent to the other copyright notices. F. Include, immediately after the copyright notices, a license notice giving the public permission to use the Modified Version under the terms of this License, in the form shown in the Addendum below. G. Preserve in that license notice the full lists of Invariant Sections and required Cover Texts given in the Document's license notice. H. Include an unaltered copy of this License. I. Preserve the section Entitled "History", Preserve its Title, and add to it an item stating at least the title, year, new authors, and publisher of the Modified Version as given on the Title Page. If there is no section Entitled "History" in the Document, create one stating the title, year, authors, and publisher of the Document as given on its Title Page, then add an item describing the Modified Version as stated in the previous sentence. J. Preserve the network location, if any, given in the Document for public access to a Transparent copy of the Document, and likewise the network locations given in the Document for previous versions if they were based on. These may be placed in the "History" section. You may omit a network location for a work that was published at least four years before the Document itself, or if the original publisher of the version it refers to gives permission. K. For any section Entitled "Acknowledgements" or "Dedications", Preserve the Title of the section, and preserve in the section all the substance and tone of each of the contributor acknowledgements and/or dedications given therein. L. Preserve all the Invariant Sections of the Document, unaltered in their text and in their titles. Section numbers or the equivalent are not considered part of the section titles. M. Delete any section Entitled "Endorsements". Such a section may not be included in the Modified Version. N. Do not retitle any existing section to be Entitled "Endorsements" or to conflict in title with any Invariant Section. O. Preserve any Warranty Disclaimers. If the Modified Version includes new front-matter sections or appendices that qualify as Secondary Sections and contain no material copied from the Document, you may at your option designate some or all of these sections as Invariant. To do this, add their titles to the list of Invariant Sections in the Modified Version's license notice. These titles must be distinct from any other section titles. You may add a section Entitled "Endorsements", provided it contains nothing but endorsements of your Modified Version by various parties—for example, statements of peer review or that the text has been approved by an organization as the authoritative definition of a standard. You may add a passage of up to five words as a Front-Cover Text, and a passage of up to 25 words as a Back-Cover Text, to the end of the list of Cover Texts in the Modified Version. Only one passage of Front-Cover Text and one of Back-Cover Text may be added by (or through arrangements made by) any one entity. If the Document already includes a cover text for the same cover, previously added by you or by arrangement made by the same entity you are acting on behalf of, you may not add another, but

you may replace the old one, on explicit permission from the previous publisher that added the old one. The author(s) and publisher(s) of the Document do not by this License give permission to use their names for publicity for or to assert or imply endorsement of any Modified Version.

5. COMBINING DOCUMENTS

You may combine the Document with other documents released under this License, under the terms defined in section 4 above to modified versions, provided that you include in the combination of the Invariant Sections of all of the original documents, unmodified, and list them all as Invariant Sections of your combined work in its license notice, and that you preserve all their Warranty Disclaimers. The combined work need only contain one copy of this License, and multiple identical Invariant Sections may be replaced with a single copy. If there are multiple Invariant Sections with the same name but different contents, make the title of each such section unique by adding at the end of it, in parentheses, the name of the original author or publisher of that section if known, or else a unique number. Make the same adjustment to the section titles in the list of Invariant Sections in the license notice of the combined work. In the combination, you must combine any sections Entitled "History" in the various original documents, forming one section Entitled "History"; likewise combine any sections Entitled "Acknowledgements", and any sections Entitled "Dedications". You must delete all sections Entitled "Endorsements".

6. COLLECTIONS OF DOCUMENTS

You may make a collection consisting of the Document and other documents released under this License, and replace the individual copies of this License in the various documents with a single copy that is included in the collection, provided that you follow the rules of this License for verbatim copying of each of the documents in all other respects. You may extract a single document from such a collection, and distribute it individually under this License, provided you insert a copy of this License into the extracted document, and follow this License in all other respects regarding verbatim copying of that document.

7. AGGREGATION WITH INDEPENDENT WORKS

A compilation of the Document or its derivatives with other separate and independent documents or works, in or on a volume of a storage or distribution medium, is called an "aggregate" if the copyright resulting from the compilation is not used to limit the legal rights of the compilation's users beyond what the individual works permit. When the Document is included in an aggregate, this License does not apply to the other works in the aggregate which are not themselves derivative works of the Document. If the Cover Text requirement of section 3 is applicable to these copies of the Document, then if the Document is less than one half of the entire aggregate, the Document's Cover Texts may be placed on covers that bracket the Document within the aggregate, or the electronic equivalent of covers if the Document is in electronic form. Otherwise they must appear on printed covers that bracket the whole aggregate.

8. TRANSLATION

Translation is considered a kind of modification, so you may distribute translations of the Document under the terms of section 4. Replacing Invariant Sections with translations requires special permission from their copyright holders, but you may include translations of some or all Invariant Sections in addition to the original versions of these Invariant Sections. You may include a translation of this License, and all the license notices in the Document, and any Warranty Disclaimers, provided that you also include the original English version of this License and the original versions of those notices and disclaimers. In case of a disagreement between the translation and the original version of this License or a notice or disclaimer, the original version will prevail. If a section in the Document is Entitled "Acknowledgements", "Dedications", or "History", the requirement (section 4) to Preserve its Title (section 1) will typically require changing the actual title.

9. TERMINATION

You may not copy, modify, sublicense, or distribute the Document except as expressly provided for under this License. Any other attempt to copy, modify, sublicense or distribute the Document is void, and will automatically terminate your rights under this License. However, parties who have received copies, or rights, from you under this License will not have their licenses terminated so long as such parties remain in full compliance.

10. FUTURE REVISIONS OF THIS LICENSE

The Free Software Foundation may publish new, revised versions of the GNU Free Documentation License from time to time. Such new versions will be similar in spirit to the present version, but may differ in detail to address new problems or concerns. See <http://www.gnu.org/copyleft/>. Each version of the License is given a distinguishing version number. If the Document specifies that a particular numbered version of this License "or any later version" applies to it, you have the option of following the terms and conditions either of that specified version or of any later version that has been published (not as a draft) by the Free Software Foundation. If the Document does not specify a version number of this License, you may choose any version ever published (not as a draft) by the Free Software Foundation. ADDENDUM: How to use this License for your documents To use this License in a document you have written, include a copy of the License in the document and put the following copyright and license notices just after the title page: Copyright (c) YEAR YOUR NAME. Permission is granted to copy, distribute and/or modify this document under the terms of the GNU Free Documentation License, Version 1.2 or any later version published by the Free Software Foundation; with no Invariant Sections, no Front-Cover Texts, and no Back-Cover Texts. A copy of the license is included in the section entitled "GNU Free Documentation License". If you have Invariant Sections, Front-Cover Texts and Back-Cover Texts, replace the "with Texts" line with this: with the Invariant Sections being LIST THEIR TITLES, with the Front-Cover Texts being LIST, and with the Back-Cover Texts being LIST. If you have Invariant Sections without Cover Texts, or some other combination of the three, merge those two alternatives to suit the situation. If your document contains nontrivial examples of program code, we recommend releasing these examples in parallel under your choice of free software license, such as the GNU General Public License, to permit their use in free software.

#academic pub.

#cc-by-sa

#pediapress



Create Your Custom Wikipedia-Book

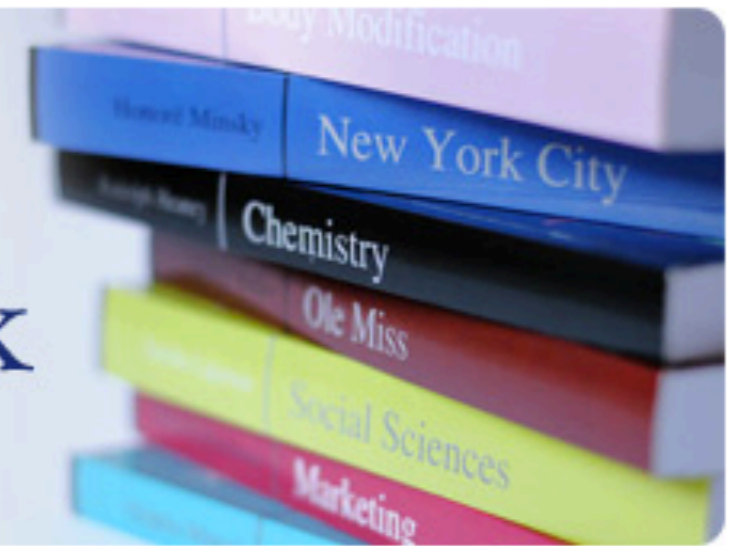

Printed Books from Wiki Content

Combine the advantages of up-to-date and in-depth knowledge with the convenience of printed books. Books are typeset and printed on demand based on your personal selection. Starting from US\$ 8.90 you get your unique book and support the Wikimedia Foundation.

[Contact page](#)

▶ [Toolbox](#)

▼ [Print/export](#)

[Create a book](#)

[Download as PDF](#)

[Printable version](#)

▼ [Languages](#)



[Български](#)

[Español](#)

[Français](#)



PediaPress pa bon !!!!

November 10, 2009 at 9:43am · [Comment](#) · [Like](#) · [Report](#)



likes this.

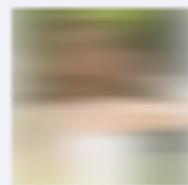

yeah.. today i made only one dowload from 8am to 5 pm.. just imagine..

November 10, 2009 at 5:52pm · [Report](#)

#academic pub.

#cc-by-sa

#pediapress

#pod

**infiltrating
academia**

Votre recherche: - Partout: alphascript

Notices 1 à 20 sur 25

Ajouter sélection au panier

Sélectionner 1-20

Tout désélectionner

 1

Sélectionner

Titre International Olympic Committee : Pierre de Coubertin, Demetrius Vikelas, Olympic Games, Winter Olympic Games, William Penny Brookes, Olympic Charter, Juan Antonio Samaranch, Olympic Cup, World Anti-Doping Agency / ed.Frederic P. Miller... [et al.]

Lieu / Dates Beau Bassin : Alphascript Publ., 2010

ISBN 9786130007812

Collation 120 p. : ill.

Service 

 2

Sélectionner

Titre 1939, German ultimatum to Lithuania : Ultimatum, Juozas Urbšys, Lithuania, Joachim von Ribbentrop, Nazi Germany, Klaipėda Region, World War I, Wehrmacht, German occupation of Czechoslovakia, appeasement, World War II / Frederic P. Miller ... [et al.] (Ed.)

Lieu / Dates Beau-Bassin : Alphascript Publ., 2010

ISBN 9786130277208

Collation 203 p. : ill.

Service 

Ajouter sélection au panier

Sélectionner 21-25

Tout désélectionner

 [21](#)

Sélectionner

Titre Judicial system of the people's republic of China :
judiciary, people's republic of China, chinese law, legal
history of China, law of the people's republic of China /
Frederic P. Miller... [et al.] (Ed.)

**Lieu /
Dates** Beau Bassin, Mauritius : Alphascript Publ., 2009

ISBN 9786130057756

Collation 153 p. : Ill.

Service 

 [22](#)

Sélectionner

Titre Legal history of China : chinese law, law of the people's
republic of China, Jiangxi-Fujian soviet, legal systems of
the world, traditional chinese law, law, rule of law,
confucianism, codification, civil code, jurisprudence /
Frederic P. Miller... [et al.] (Ed.)

**Lieu /
Dates** Beau Bassin, Mauritius : Alphascript Publ., 2009

ISBN 9786130045258

Collation 162 p. : ill.

Service 

@lphascript publishing

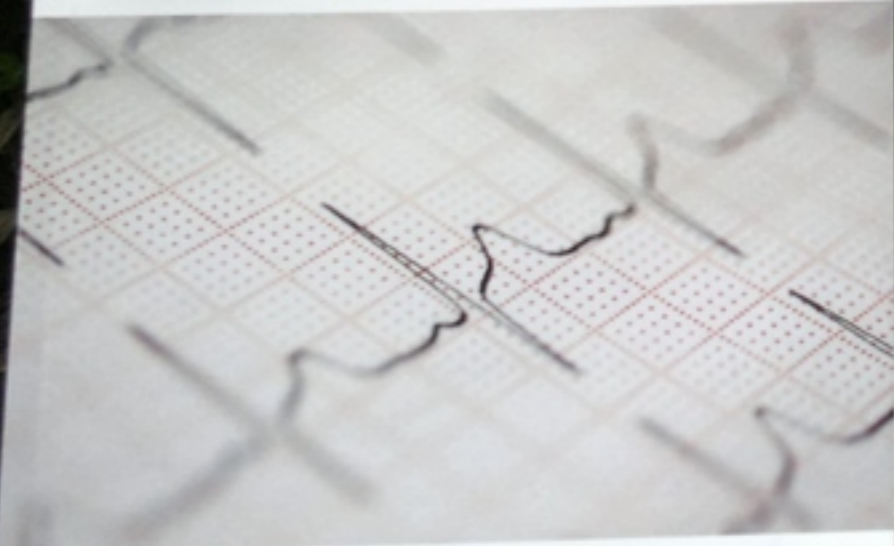

Frederic P. Miller, Agnes F. Vandome, John
McBrewster (Ed.)

Neuroéconomie

Neurosciences cognitives, Émotion, Cognitif, Décision,
Investissement, Achat, Risque, Neurosciences
, Économie



NELA
158653

βetascript
publishing

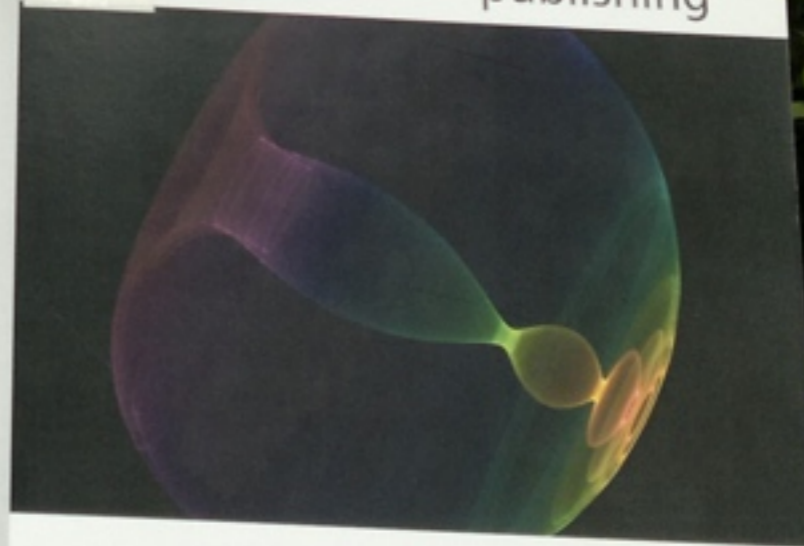

Paulus Vladimiri

Cracow Academy, Teutonic Knights, Prague University,
Canon Law (Catholic Church), Kraków



Lambert M. Surhone,
Mariam T. Tenhoe, Susan F. Henssonow (Ed.)

JORGE LUIS BORGES



alphascript publishing

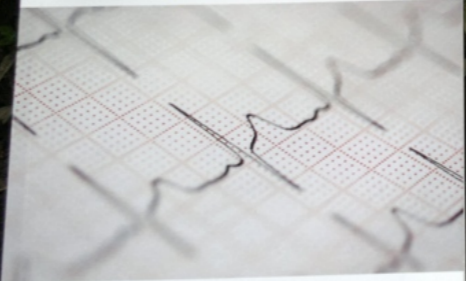

Frederic P. Miller, Agnes F. Vandome, John
McBrewster (Ed.)

Neuroéconomie

Neurosciences cognitives, Émotion, Cognitif, Décision,
Investissement, Achat, Risque, Neurosciences
, Économie

NELA
158653

betascript
publishing

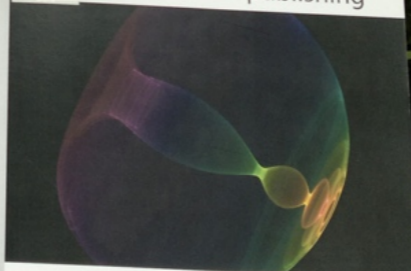

Paulus Vladimiri

Cracow Academy, Teutonic Knights, Prague University,
Canon Law (Catholic Church), Kraków

943
.8
Quality
Content
by WIKIPEDIA
articles!

Lambert M. Surhone,
Mariam T. Ternoje, Susan F. Henssonow (Ed.)

**failed the #spam
detection test**



6WPA5

Aram Bartholl, Are you human?, 2010





wiki-sprint









techniques. These were then... by NOTV, Atmospherix, and... Makela curated a DVD for... Forum called "LIVE CINEMA... ing on the emerging sister... cinema". Individual VJs... published DVDs and CD-ROMs... including Eclectic Method's... (2002) and Eclectic Method's... (2005), as well as eyewash's... and their "DVD3" (2008).

Books reflecting on the history... pects, and theoretical issues... such as "The VJ Book: Inspirational... cal Advice for Live Visuals Perform... Spinrad, 2005), "VJ: Audio-Visual... Culture" (Michael Faulkner and... "vE-jA: Art + Technology of Live... (Xárene Eskandar [ed], 2006),... Cinema Unraveled" (Tim Jaeger... subject of VJ-DJ collaboration... become a subject of interest for... in the field of academic human-computer... action (HCI).

1.5.2 Technological developments

The availability and affordability... sumer-level technology allowed... people to get involved into Vjing. The... increase in computer processing...



Fig. 5 — The Edirol V-4 video mixer.

...came available facilitated more compact, yet of-... ten more complex setups, sometimes allowing... VJs to bypass using a video mixer, using pow-... erful computers running VJ software to control... their mixing instead. However, many VJs con-... tinue to use video mixers with multiple sources... which allows flexibility for a wide range of input... devices and a level of security against comput-... er crashes or slowdowns in video playback due... to overloading the CPU of computers due to the... demanding nature of realtime video processing.

In 2001, Roland / Edirol released the V4... Video mixer, a popular video mixer designed... specifically for Vjing. It features MIDI control

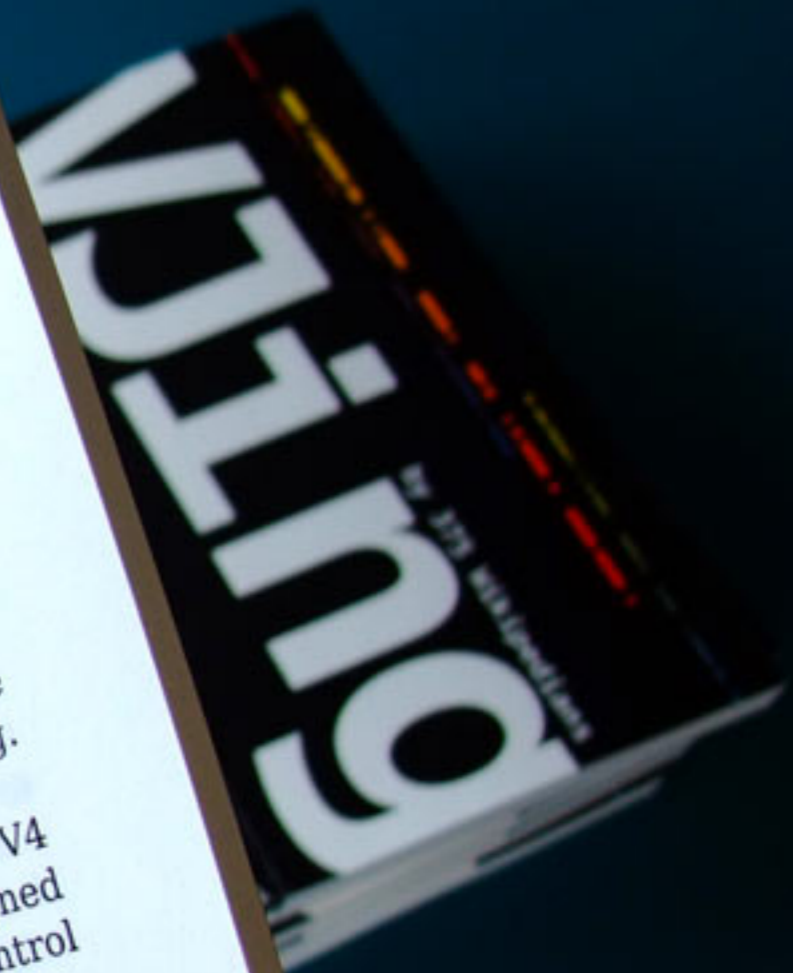

Image Sources, Licenses and Contributors

Fig. 1: Vj with two sources.jpg
Source: http://en.wikipedia.org/w/index.php?title=File:Vj_with_two_sources.jpg

Author: Carriegates
Description: This image shows a VJ mixing two videos together from different laptops.
Date: 21 June 2007
Source: Own work



License: Creative Commons Attribution-Sharealike 3.0

Fig. 2: 3b39656t.gif
Source: <http://en.wikipedia.org/w/index.php?title=File:3b39656t.gif>
Author: Underwood & Underwood

Description: Mary Hallock Greenewalt, half-length portrait, at electric light "color organ", which she invented



Date: 28 April 1925
Source: Mary_Hallock_Greenewalt_with_light_organ
License: Public Domain

Fig. 3: Videonics mx pro.jpg
Source: http://en.wikipedia.org/w/index.php?title=File:Videonics_mx_pro.jpg



Image Sources, Licenses and Contributors
Author: Carriegates
Description: This is a picture of the Videonics MX-Pro. It is one of the more basic models of analog video mixers and is quite popular with emerging VJs.
Date: 1 January 2008
Source: Own work
License: Public Domain



Fig. 4: VJs at motion picture festival 2009.jpg
Source: http://en.wikipedia.org/w/index.php?title=File:VJs_at_motion_picture_festival_2009.jpg
Author: Carriegates
Description: Two VJs collaborating at an outdoor electronic music festival.
Date: 18 July 2009
Source: Own work
License: Public Domain

Fig. 5: Video Edirol V-4
Source: http://en.wikipedia.org/w/index.php?title=File:Edirol_V-4.jpg
Author: Carriegates
Description: Edirol V-4
Source: Own work
License: Public Domain



License: Attribution-Share Alike

**we have decided
to block this title**

**the title closely
matches content that
is freely available on
the web...**

**...and we are not
confident
that you hold
exclusive
publishing rights.**

content guidelines:

content guidelines:

**we will not accept
content that is freely
available on the web**

content guidelines:

**...unless you are the
copyright owner of
that content.**

#conclusion?

Thank you !

Thank you !

for being still awake